

## UB100

# Communicative heating controller, BACnet MS/TP



### Summary

**UB100 is a communicative room heating controller with two inputs and one on-off/PWM output for control of a radiator or electrical heater. It can work autonomously, or in connection to a primary controller or building management system over BACnet MS/TP.**

### Application

- **Systems with radiators, electric heaters, or floor heating – control and measuring of room temperature**
- **Systems with heating and cooling panels with change-over signal sent over the bus – control and measuring of room temperature**

### Function

The controller reads actual room temperature, setpoint shift by a knob, and set operation status which is set by short push of the knob. The room temperature is measured in the range of 0 to +50 °C. Measured and set values are processed in a PI algorithm, at the output of which there is a PWM controlled triac. All values are displayed on a large LCD display.

The controller contains real time clock with a weekly scheduler (6 events per day). It changes between three operation modes: Day, Night, and Off. A short push in the Night mode switches to Party mode – Comfort extension by 2 hours.

The digital inputs read signals from a window contact and presence sensors. They can be used optionally.

The change-over mode is set by writing into the Change-over BACnet variable, see PICS below. The controller switches after safety timeout of 30 min.

The communication bus is RS485 with BACnet MS/TP protocol, therefore the controllers are easily to integrate into most of the up-to-date SCADA or BMS system. See the BACnet PICS in Annex 1 below.

## Technical data

Power	24 V AC+/- 10%
Consumption	1400 mVA + peripherals (appr. 5VA)
Measuring range	0 ÷ 50 °C
Protection	IP20
Sensor accuracy	+/- 1,5 K (with software correction)
Inputs	2x potential-free contacts, 24VAC, 5mA
Output	1x solid state relay, zero switching, for AC load, 24 V AC, maximum current 0,4A
Setpoint correction	according to configuration, +/- 10 to +/- 1 K
Communication	2 wire RS485 – BACnet MS/TP
Display	LCD 60 x 60 mm
Terminals	screw terminals for 0,14 – 1,5 mm <sup>2</sup> wires
Cover	ABS, RAL9010 or another
Weight	0,13 kg
Dimensions	see below

## Terminals

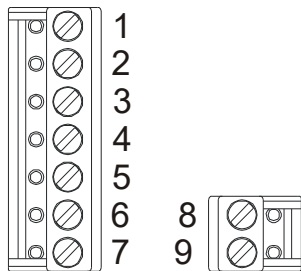

- 1: DI1 presence input (dry contact to G0)
- 2: DI2 window contact input (dry contact to G0)
- 3: DO1 heating output (24 V against G0)
- 4: N/C not used
- 5: G0 power, inputs, outputs – reference point
- 6: G0 power, inputs, outputs – reference point
- 7: G power
  
- 8: K- communication RS485 -
- 9: K+ communication RS485 +

## DIP switches

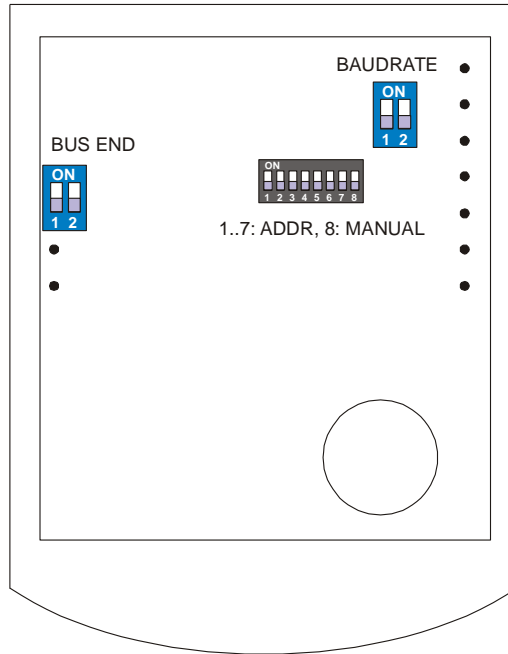

Back of the PCB

**BUS END:** if both ON, the bus is terminated (if last device on the line)

**BAUDRATE:** 00 – 9600 bps (default)

01 – 19200 bps

10 – 38400 bps

11 – 76800 bps

This setting applies only if switch 8 (MANUAL) is ON

**ADDR:** Switches 1...7 are used for manual setting of the MS/TP address in binary form.

Example:

1000000 addr. 1

1011000 addr. 13 (= 1 + 0 + 4 + 8)

This setting applies only if switch 8 (MANUAL) is ON

Switch 8 activates MANUAL settings of the MS/TP address and baudrate. If the switch 8 is OFF, software settings from the EEPROM are used.

## Installation

Units are intended for operating in a normal and chemically non-aggressive environment. They do not need any servicing or maintenance. Install them in a vertical position at places where they can be operated easily and measure correct values of temperature, i.e. in the height of about 150 cm, with no direct sunlight or other heat / cool source (AHU outlets, refrigerator, electrical appliances). The device consists of two parts: bottom with screw terminal block and cover containing PCB, display, and the knob. The bottom part is fixed by 2 or 4 screws to any flat surface or a flush-mounting box  $\varnothing$  50 mm. At the back of the bottom there is an aperture for cabling. The bottom should be installed and cabling connected first, and the upper part inserted after the construction works have been finished to prevent damage to the unit.

## Opening the cover

When removing the display part, proceed as follows:

- press gently the side parts of the unit and pull the right of the display part by several millimeters
- pull the left of the display part
- pull the display part and remove it from the bottom.

Do not bend the display part too much, the connector pins could be damaged. The locks are only at the sides of the display part, not at the top nor bottom.

## Starting sequence

After power-up, following items are displayed:

- display test (all segments active)
- 1: FW version (e.g. **1.25**)
- 2: MS/TP address (e.g. **13 A**)
- 3: Baudrate (coded 0, 1, 2, 3 – see above, **br 0** = 9600 bps)
- 4: Number of EEPROM writing cycles (for service purposes only)

After this sequence is completed, the controller starts normal operation.

## Operation

### Temperature correction:

Turn the knob clockwise to increase setpoint, turn it counterclockwise to decrease setpoint. The maximum correction range can be modified over the bus e.g. with the domat.exe configuration tool.

### Operation mode change:

Push the knob shortly (<1 s). Each push changes the operation mode to Party – Day – Night – Off – Auto.

In the Auto mode, the Day / Night / Off modes change according to time schedule). The Party mode overrides to Comfort for 120 minutes, then follows the actual time schedule.

The weekly time schedule switches between Day, Night, and Off modes according to the event list. There may be up to 6 events per day.

### Time schedule settings:

It is possible to set the time scheduler over the BACnet communication only. The user can change between the operating modes using the knob.

### Change of setpoints and controller time:

Switch to the settings mode with a superlong push (>2.5 s). The controller switches to settings mode (flashing thermometer icon).

### Turning the knob selects between following settings:

- Controller time and day of week (Clock icon, Day of week)
- Setpoint temp. Heating Day mode (Temperature, Heating, Day are flashing)
- Setpoint temp. Heating Night mode (Temperature, Heating, Night are flashing)
- Setpoint temp. Heating Off mode (Temperature, Heating, Empty house are flashing)
- Setpoint temp. Cooling Day mode (Temperature, Cooling, Day are flashing)
- Setpoint temp. Cooling Night mode (Temperature, Cooling, Night are flashing)
- Setpoint temp. Cooling Off mode (Temperature, Cooling, Empty house are flashing)

Select the requested value by a short push. Turn knob to change value. Confirm by a short push again.

If there is no user activity for 30 s, the controller goes to the basic display mode.

### Default values:

The default values as well as all other settings (PI parameters, address, baudrate...) can be set by the configuration program, UB Tool. To be able to communicate with the controllers, a MS/TP to TCP router must be used, e.g. Contemporary Controls BAS Router.

### Dimensions

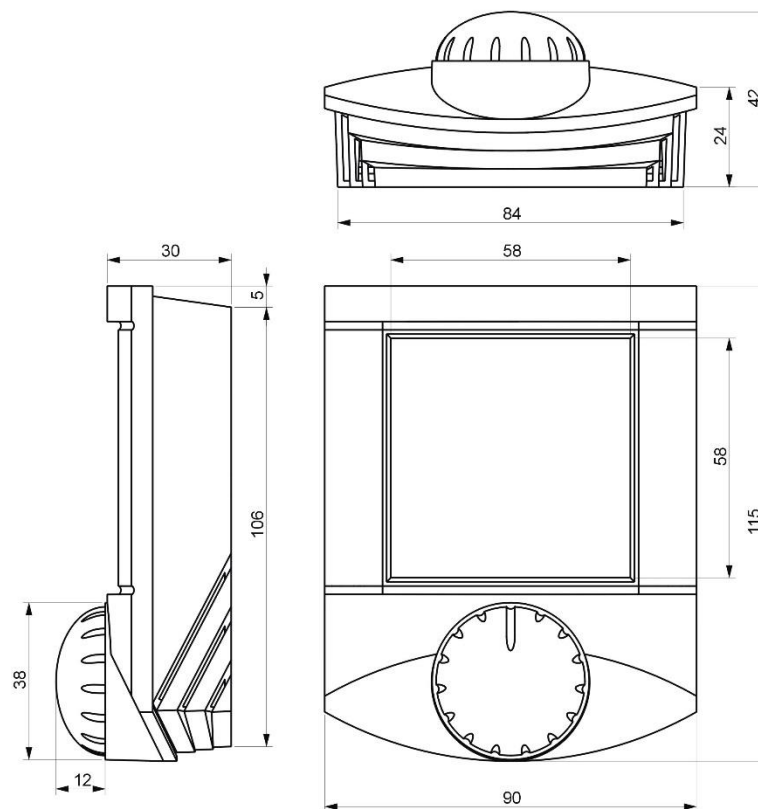

### RoHS notice

The device contains a non-rechargeable battery which backups the real-time clock and part of the memory. After the device is not operable, please return it to the manufacturer or dispose of it in compliance with local regulations.

## Annex 1

### BACnet Protocol Implementation Conformance Statement

Document Revision: 1.11

Date: 25.09.15

Vendor Name: Domat Control System s.r.o.

Vendor Number: 384

Product Name: BACnet room controller

Product Model Number: **UB100**

Hardware Revision: V1.1

Firmware Revision: V102

BACnet Protocol Revision: 135-2001 (1)

#### Product Description:

The UB100 series BACnet communicating thermostat have been specifically designed for integrated room controls of heating and cooling applications (radiators, cooling panels) to be monitored on a BACnet MS-TP® network.

#### BACnet Standardized Device Profile (Annex L):

- BACnet Operator Workstation (B-OWS)
- BACnet Building Controller (B-BC)
- BACnet Advanced Application Controller (B-AAC)
- BACnet Application Specific Controller (B-ASC)
- BACnet Smart Sensor (B-SS)
- BACnet Smart Actuator (B-SA)

**List all BACnet Interoperability Building Blocks Supported (Annex K):** The UB100 BACnet communicating thermostat meets all requirements for designation as an Application Specific Controller (B-ASC). The BACnet thermostat series supports the following BACnet Interoperability Building Blocks (BIBBs):

Tab.1

Application Service	Designation	BACnet Service
Data Sharing	DS-RP-B	Read Property
Data Sharing	DS-RPM-B	Read Property Multiple
Data Sharing	DS-WP-B	Write Property
Data Sharing	DS-COV-B	COV
Device Management	DM-DDB-B	Receive Who-Is, send I-Am
Device Management	DM-DOB-B	Receive Who-has, send I-have
Device Management	DM-DCC-B	Device Communication Control
Device Management	DM-TS-B	Time Synchronization
Device Management	DM-RD-B	Reinitialize Device
Scheduling	SCHED-I-B	Internal scheduler

**Standard Object Types Supported:**

An object type is supported if it may be present in the device. For each standard Object Type supported provide the following data:

**Tab.2**

Object type	Supported Objects	Dynamically Creatable	Dynamically Deletable	Optional Property Supported	Writable Properties
Analog Input	<input checked="" type="checkbox"/>	<input type="checkbox"/>	<input type="checkbox"/>		
Analog Value	<input checked="" type="checkbox"/>	<input type="checkbox"/>	<input type="checkbox"/>		
Binary Input	<input checked="" type="checkbox"/>	<input type="checkbox"/>	<input type="checkbox"/>		
Binary Output	<input checked="" type="checkbox"/>	<input type="checkbox"/>	<input type="checkbox"/>		
Binary Value	<input checked="" type="checkbox"/>	<input type="checkbox"/>	<input type="checkbox"/>		
Multi State Value	<input checked="" type="checkbox"/>	<input type="checkbox"/>	<input type="checkbox"/>		
Multi State Input	<input checked="" type="checkbox"/>	<input type="checkbox"/>	<input type="checkbox"/>		
Device	<input checked="" type="checkbox"/>	<input type="checkbox"/>	<input type="checkbox"/>		
Calendar	<input checked="" type="checkbox"/>	<input type="checkbox"/>	<input type="checkbox"/>		
Schedule	<input checked="" type="checkbox"/>	<input type="checkbox"/>	<input type="checkbox"/>		

**Object Property Support Table**

**Tab.3**

List of properties	Device	BI	BO	BV	AI	AV	MV	MI	SCH	CAL
Object Identifier	<input checked="" type="checkbox"/>	<input checked="" type="checkbox"/>	<input checked="" type="checkbox"/>	<input checked="" type="checkbox"/>	<input checked="" type="checkbox"/>	<input checked="" type="checkbox"/>	<input checked="" type="checkbox"/>	<input checked="" type="checkbox"/>	<input checked="" type="checkbox"/>	<input checked="" type="checkbox"/>
Object Name	<input checked="" type="checkbox"/>	<input checked="" type="checkbox"/>	<input checked="" type="checkbox"/>	<input checked="" type="checkbox"/>	<input checked="" type="checkbox"/>	<input checked="" type="checkbox"/>	<input checked="" type="checkbox"/>	<input checked="" type="checkbox"/>	<input checked="" type="checkbox"/>	<input checked="" type="checkbox"/>
Object Type	<input checked="" type="checkbox"/>	<input checked="" type="checkbox"/>	<input checked="" type="checkbox"/>	<input checked="" type="checkbox"/>	<input checked="" type="checkbox"/>	<input checked="" type="checkbox"/>	<input checked="" type="checkbox"/>	<input checked="" type="checkbox"/>	<input checked="" type="checkbox"/>	<input checked="" type="checkbox"/>
Description	<input checked="" type="checkbox"/>	<input checked="" type="checkbox"/>	<input checked="" type="checkbox"/>	<input checked="" type="checkbox"/>	<input checked="" type="checkbox"/>	<input checked="" type="checkbox"/>	<input checked="" type="checkbox"/>	<input checked="" type="checkbox"/>	<input checked="" type="checkbox"/>	<input checked="" type="checkbox"/>
System Status	<input checked="" type="checkbox"/>									
Vendor Name	<input checked="" type="checkbox"/>									
Vendor Identifier	<input checked="" type="checkbox"/>									
Model Name	<input checked="" type="checkbox"/>									
Firmware Revision	<input checked="" type="checkbox"/>									
Protocol Version	<input checked="" type="checkbox"/>									
Location	<input checked="" type="checkbox"/>									
Services Supported	<input checked="" type="checkbox"/>									
Object Types Supported	<input checked="" type="checkbox"/>									
Object List	<input checked="" type="checkbox"/>									

Max Master	<input checked="" type="checkbox"/>									
Max Info Frames	<input checked="" type="checkbox"/>									
Database Revision	<input checked="" type="checkbox"/>									
Number Of APDU Retries	<input checked="" type="checkbox"/>									
APDU Timeout	<input checked="" type="checkbox"/>									
Max APDU Length	<input checked="" type="checkbox"/>									
Local Time	<input checked="" type="checkbox"/>									
Local Date	<input checked="" type="checkbox"/>									
UTC Offset	<input checked="" type="checkbox"/>									
Present Value		<input checked="" type="checkbox"/>	<input checked="" type="checkbox"/>	<input checked="" type="checkbox"/>	<input checked="" type="checkbox"/>	<input checked="" type="checkbox"/>	<input checked="" type="checkbox"/>	<input checked="" type="checkbox"/>	<input checked="" type="checkbox"/>	<input checked="" type="checkbox"/>
Units					<input checked="" type="checkbox"/>	<input checked="" type="checkbox"/>				
Status Flags		<input checked="" type="checkbox"/>	<input checked="" type="checkbox"/>	<input checked="" type="checkbox"/>	<input checked="" type="checkbox"/>	<input checked="" type="checkbox"/>	<input checked="" type="checkbox"/>	<input checked="" type="checkbox"/>		
Event State		<input checked="" type="checkbox"/>	<input checked="" type="checkbox"/>	<input checked="" type="checkbox"/>	<input checked="" type="checkbox"/>	<input checked="" type="checkbox"/>	<input checked="" type="checkbox"/>	<input checked="" type="checkbox"/>		
Active text		<input checked="" type="checkbox"/>	<input checked="" type="checkbox"/>	<input checked="" type="checkbox"/>						
Inactive text		<input checked="" type="checkbox"/>	<input checked="" type="checkbox"/>	<input checked="" type="checkbox"/>						
Device type		<input checked="" type="checkbox"/>	<input checked="" type="checkbox"/>		<input checked="" type="checkbox"/>					
Resolution					<input checked="" type="checkbox"/>					
Maximal Value					<input checked="" type="checkbox"/>					
Minimal Value					<input checked="" type="checkbox"/>					
Reliability					<input checked="" type="checkbox"/>					
Number Of States							<input checked="" type="checkbox"/>	<input checked="" type="checkbox"/>		
State Text							<input checked="" type="checkbox"/>	<input checked="" type="checkbox"/>		
COV Increment					<input checked="" type="checkbox"/>					
Out Of Service		<input checked="" type="checkbox"/>	<input checked="" type="checkbox"/>	<input checked="" type="checkbox"/>	<input checked="" type="checkbox"/>	<input checked="" type="checkbox"/>	<input checked="" type="checkbox"/>	<input checked="" type="checkbox"/>	<input checked="" type="checkbox"/>	
Priority Array			<input checked="" type="checkbox"/>	<input checked="" type="checkbox"/>		<input checked="" type="checkbox"/>	<input checked="" type="checkbox"/>	<input checked="" type="checkbox"/>		
Priority For Writing									<input checked="" type="checkbox"/>	
List Of Object Property References									<input checked="" type="checkbox"/>	
Effective Period									<input checked="" type="checkbox"/>	
Date List										<input checked="" type="checkbox"/>



### Analog Input Object Instance Summary

Tab.4

Object Name	Type and ID	Units	Access Type	Description	MB Reg. add
Module ID.	AI0	Numeric	R	Module type identification	1 LSB 1 MSB
PID output Heating	AI1	Percent (%)	R	Heating routine output	8 LSB
PID output Cooling	AI2	Percent (%)	R	Cooling routine output	8 MSB
Room sensor	AI3	Cel. / Fahr.	R	Actual temperature measured by the internal sensor	21
Sys. Malfunction code	AI4	No units	R	Reserved, not used	

### Analog Value Object Instance Summary

Tab.5

Object Name	Type and ID	Units	Access Type	Description	MB Reg. add
Manual Heating	AV0	Percent (%)	R/W	User requested value for Heating. Is used when the object "Heating manual control" is inactive (state manual).	11 LSB
Manual Cooling	AV1	Percent (%)	R/W	User requested value for Cooling. Is used when the object "Cooling manual control" is inactive (state manual).	11 MSB
SP correction	AV2	Cel. / Fahr.	R/W	Set point correction set by user	12
SP Heating	AV3	Cel. / Fahr.	R	Demanded room temperature in heating mode	13
SP Cooling	AV4	Cel. / Fahr.	R	Demanded room temperature in cooling mode	14
SP day/comfort Heating	AV5	Cel. / Fahr.	R/W	Day/comfort mode heating temperature set point set by user	15
SP night/ pre comfort Heating	AV6	Cel. / Fahr.	R/W	Night/standby mode heating temperature set point set by user	16
SP depression/ economy Heating	AV7	Cel. / Fahr.	R/W	Off mode heating temperature set point set by user	17
SP day/comfort Cooling	AV8	Cel. / Fahr.	R/W	Day/comfort mode cooling temperature set point set by user	18
SP night/ pre comfort Cooling	AV9	Cel. / Fahr.	R/W	Night/standby mode cooling temperature set point set by user	19
SP depression/ economy Cooling	AV10	Cel. / Fahr.	R/W	Off mode cooling temperature set point set by user	20

Outside sensor	AV11	Cel. / Fahr.	R/W	Actual outside temperature, may be written to RAM optionally for display	22
Min rel. temp correction	AV12	Cel. / Fahr.	R/W	Minimum relative user temperature correction, a positive value is saved and is taken as negative limit	33
Max rel. temp correction	AV13	Cel. / Fahr.	R/W	Maximum relative user temperature correction	34
Min day, night, depression temp	AV14	Cel. / Fahr.	R/W	Minimum temperature which user can set as set point for day, night, and off modes	35
Max day, night, depression temp	AV15	Cel. / Fahr.	R/W	Maximum temperature which user can set as set point for day, night, and off modes	36
Room sensor correction	AV16	Cel. / Fahr.	R/W	Correction: adds to the actual temperature measured by the internal sensor	37
P band*	AV17	No units	R/W	Specified for factory proprietary settings	27
I const*	AV18	No units	R/W	Specified for factory proprietary settings	28
TPSS 1*	AV19	No units	R/W	Specified for factory proprietary settings	29,41,43
TPSS 2*	AV20	No units	R/W	Specified for factory proprietary settings	45,46
TPSS 3*	AV21	No units	R/W	Specified for factory proprietary settings	42
TPSS 4*	AV22	No units	R/W	Specified for factory proprietary settings	44
Schedule Output	AV23	No units	R/W		
Factory set command	AV24	No units	W	Specified factory settings (defaults) recovering:  25545 – reinitialize object name;  5119 – clear object settings scheduler and calendar except object name settings;  61731 – reinitialize scheduler and calendar	

Note: SP-Set Point, '\*'-usable for vendor only

### Binary Input Object Instance Summary

Tab.6

Object Name	Type and ID	Active/Inactive Value	Access Type	Description	MB Reg. add
Occupancy Input	BI0	closed/opened	R	Hardware digital input (physical level)	7 MSB-0
Window Input	BI1	closed/opened	R	Hardware digital input (physical level)	7 MSB-1
Heating request	BI2	demanded/satisfied	R	Heating request PID heating > 5%	7 MSB-2
Cooling request	BI3	demanded/satisfied	R	Cooling request PID heating > 5%	7 MSB-3

**Binary Output Object Instance Summary**  
**Tab.7**

Object Name	Type and ID	Active/Inactive Value	Access Type	Description	MB Reg. add
Relay 1	BO0	on/off	R	Heating output	7 LSB-0
Relay 2	BO1	on/off	R	Cooling output	7 LSB-1

**Binary Value Object Instance Summary**  
**Tab.8**

Object Name	Type and ID	Active/Inactive Value (default value is bolded)	Access Type	Description	MB Reg. add
Heating manual control (Relay1)	BV0	<b>auto</b> /manual	R/W	UB100 has only one output (heat/cool). The function is not active if Change-over is enabled.	10 LSB-1
Cooling manual control (Relay2)	BV1	<b>auto</b> /manual	R/W		10 LSB-2
Presence mode	BV2	<b>residential</b> /hotel	R/W		26 LSB-0
Temperature correction display	BV3	<b>absolute</b> / relative	R/W		26 LSB-1
Valve exercising	BV4	<b>enabled</b> /disabled	R/W		26 LSB-4
Valve polarity	BV5	<b>N.O./N.C.</b>	R/W		26 LSB-5
Temperature correction reset	BV6	<b>enabled</b> /disabled	R/W		26 LSB-6
Control mode	BV7	on-off / <b>PI</b>	R/W		26 LSB-7
Occupancy Input status	BV8	<b>enabled</b> /disabled	R/W		26 MSB-0
Window Input status	BV9	<b>enabled</b> /disabled	R/W		26 MSB-1
Occupancy Input sense	BV10	<b>N.O./N.C.</b>	R/W		26 MSB-2
Window Input sense	BV11	<b>N.O./N.C.</b>	R/W		26 MSB-3
SWST*	BV12	Edit / <b>lock</b>	R/W	Specified trigger for one time system settings changing permission.	
Daylight saving	BV13	enabled/ <b>disabled</b>	R/W	Power restart needed	
Change-over	BV14	enabled/ <b>disabled</b>	R/W	Active (cooling) / inactive (heating), set if the controller shall activate its output on cooling sequence rather than on heating sequence. There are 30 minutes protection delay.	10 LSB-5

Fahrenheit	BV15	enabled/ <b>disabled</b>	R/W	Active (Fahrenheits) / inactive (Celsius) temperature related object changes accordingly units; setpoint values are set to default values in Fahrenheits/Celsius	29 LSB-0
------------	------	--------------------------	-----	---	----------

Note: \*-usable for vendor only

**Multi-state Input Object Instance Summary**

**Tab.9**

Object Name	Type and ID	Access Type	Number of States	States Text	Description	MB Reg. add
Presence state Hotel mode	MI0	R/W	3	Comfort	1-Comfort(occupied house)	25 LSB -0
				Standby	2-Standby (empty house)	25 LSB -1
				Off	3-Energy savings (off)	25 LSB -2
Presence state Residential mode	MI1	R/W	3	Day	1- Day (sun + occupied house)	25 LSB -0
				Night	2-Night (moon + occupied house)	25 LSB -1
				Depression	3-Depression (empty house)	25 LSB -2

**Multi-state Value Object Instance Summary**

**Tab.10**

Object Name	Type and ID	Access Type	Number of States	States Text	Description	MB Reg. add
Set presence Hotel mode	MV0	R/W	3	Comfort	1 - Comfort (occupied house)	23 LSB -0
				Standby	2 - Standby (empty house)	23 LSB -1
				Off	3 - Energy savings (off)	23 LSB -2
Set presence Residential mode	MV1	R/W	5	Day	1 - Day (sun + occupied house)	23 LSB -0
				Night	2 - Night (moon + occupied house)	23 LSB -1
				Depression	3 - Depression (empty house)	23 LSB -2
				Auto	4 - Auto (clock)	23 LSB -3
				Party	5 - Party (after 2 hrs go to auto)	23 LSB -4

**Schedule Object Instance Summary**

**Tab.11**

Object Name	Type and ID	Access Type	States	Description
Schedule	SCH0	R/W	Day / Comfort Night / Standby Depression / Energy saving	1 - Day / Comfort 2 - Night / Standby 4 - Depression / Energy saving Six changes per day in weekly schedule.

**Calendar Object Instance Summary**

**Tab.12**

Object Name	Type and ID	Access Type	Description
Calendar-Holidays	CALO	R/W	

**List of Property Value Range Restrictions**

**Tab.13**

Object Name	Type and Instance ID	Units	Under Range Value	Over Range Value	Default value
PID output Heating	AI1	Percent (%)	0 %	100 %	0 %
PID output Cooling	AI2	Percent (%)	0 %	100 %	0 %
Room sensor	AI3	Cel. / Fahr.	-10.0°C / 14.0°F	+80.0°C / 178.0°F	N/A
Manual Heating	AV0	Percent (%)	0 %	100 %	0 %
Manual Cooling	AV1	Percent (%)	0 %	100 %	0 %
SP (setpoint) correction	AV2	Cel. / Fahr.	-100°C / °F	100°C / °F	0°C / °F
SP Heating	AV3	Cel. / Fahr.	0°C / °F	100°C / °F	0°C / °F
SP Cooling	AV4	Cel. / Fahr.	0°C / °F	100°C / °F	0°C / °F
SP day/comfort Heating	AV5	Cel. / Fahr.	0°C / °F	100°C / °F	21°C / 70°F
SP night/ pre comfort Heating	AV6	Cel. / Fahr.	0°C / °F	100°C / °F	19°C / 66°F
SP depression/ economy Heating	AV7	Cel. / Fahr.	0°C / °F	100°C / °F	12°C / 54°F
SP day/comfort Cooling	AV8	Cel. / Fahr.	0°C / °F	100°C / °F	24°C / 75°F
SP night/ pre comfort Cooling	AV9	Cel. / Fahr.	0°C / °F	100°C / °F	26°C / 79°F
SP depression/ economy Cooling	AV10	Cel. / Fahr.	0°C / °F	100°C / °F	35°C / 95°F
Outside sensor	AV11	Cel. / Fahr.	-100°C / °F	100°C / °F	0°C / 0°F
Min rel. temp correction	AV12	Cel. / Fahr.	-100°C / °F	0°C / °F	-3.5°C / -6°F
Max rel. temp correction	AV13	Cel. / Fahr.	0°C / °F	100°C / °F	3.5°C / 6°F
Min day, night, depression temp	AV14	Cel. / Fahr.	0°C / °F	100°C / °F	10°C / 50°F
Max day, night, depression temp	AV15	Cel. / Fahr.	0°C / °F	100°C / °F	40°C / 104°F

Room sensor correction	AV16	Cel. / Fahr.	-100°C / °F	100°C / °F	-3.1°C / 5.6°F
P band (in tenth)	AV17	Kel. / Fahr.	0 K	100 K	2 K
I const	AV18	seconds	0 s	65535 s	3600 s
Maximal calendar entry per object	CAL0	No units	0	50	0

Note:N/A- Not applicable.

**Data Link Layer Options:**

- BACnet IP, (Annex J)
- BACnet IP, (Annex J), Foreign Device
- ISO 8802-3, Ethernet (Clause 7)
- ANSI/ATA 878.1, 2.5 Mb. ARCNET (Clause 8)
- ANSI/ATA 878.1, RS-485 ARCNET (Clause 8), baud rate(s) \_\_\_\_\_
- MS/TP master (Clause 9), baud rate(s): 9600, 19200, 38400, 76800
- MS/TP slave (Clause 9), baud rate(s): \_\_\_\_\_
- Point-To-Point, EIA 232 (Clause 10), baud rate(s): \_\_\_\_\_
- Point-To-Point, modem, (Clause 10), baud rate(s): \_\_\_\_\_
- LonTalk, (Clause 11), medium: \_\_\_\_\_
- Other: \_\_\_\_\_

**Segmentation Capability:**

- Segmented requests supported                      Window Size \_\_\_\_\_
- Segmented responses supported                      Window Size \_\_\_\_\_

**Note 1:** The thermostat does not support segmented requests or responses

**Device Address Binding:**

Is static device binding supported? (This is currently necessary for two-way communication with MS/TP slaves and certain other devices.)  Yes     No

**Networking Options:**

- Router, Clause 6 - List all routing configurations, e.g., ARCNET-Ethernet, Ethernet-MS/TP, etc.
- Annex H, BACnet Tunneling Router over IP
- BACnet/IP Broadcast Management Device (BBMD)  
Does the BBMD support registrations by Foreign Devices?  Yes     No

**Character Sets Supported:**

Indicating support for multiple character sets does not imply that they can all be supported simultaneously.

- ANSI X3.4                                       IBM™/Microsoft™ DBCS                       ISO 8859-1
- ISO 10646 (UCS-2)                       ISO 10646 (UCS-4)                       JIS C 6226

**If this product is a communication gateway, describe the types of non-BACnet equipment/networks(s) that the gateway supports:**

\_\_\_\_\_

\_\_\_\_\_

\_\_\_\_\_

**Changes in  
versions**

10/2015 – From firmware version 102 is supported unit Fahrenheit degree and internal time scheduler. From this HW revision is supported 2 potential free contacts.  
10/2023 – Change of the logo