

order number

w751-9301 DDC controller



Summary

DDC (Direct digital control) controller w751-9301 is free programmable process station with Cortex A7, 650 MHz processor and Linux OS. It contains two Ethernet ports, 4× AI, 8× DI, 2× AO, 4× DO and RS485 interface. Controller is suitable for control of larger installations (approximately 400 to 500 physical data points).

Application

- Free programmable control unit for HVAC systems and other applications with web access
- Data acquisition, processing, and presentation systems with advanced networking features
- Protocol converters with web data presentation (must be programmed by user)

Function

The controller hosts an embedded Linux operating system which boots up the Domat runtime with the application. The board contains real time clock with battery backup, flash memory containing OS, runtime, application, and other data (time programs, setpoints etc.), and a watchdog. It is also possible to use NVRAM to backup parameters in case of unexpected system shutdown.

The application is created and uploaded in the Domat IDE development environment. The maximum application program size depends on number of physical and software data points, amount of function blocks which require more memory (e.g. time schedulers), degree of code optimisation, and number of connections the PLC has to handle.

For communication with other devices, IMIOs contain 2× Ethernet ports. I/Os integrated on the board are 2× AI (temperature), 2× AI (voltage), 2× AO, 8× DI and 4× DO and RS485 interface.

Controller has sufficient computing power to control larger installation with external I/O modules and communication channels (for example Modbus TCP server, SSCP client, ...).

The process station contains a web server for remote connection and user intervention. The web pages are created in Domat IDE which is also used for uploading the exported web definition to the process station. From the security point of view, the website is not recommended for use in the public network, it is intended for operation in a local network., Therefore it is necessary to integrate the configured router or other element that ensures network security during the design of the network topology.

Module is 108 mm wide and mounts on a standard DIN rail.

Technical data

Power	24 V DC (-15...+20 %), 4.6 W, push-in cage clamps
Operating temperature	-25...60 °C
Admissible humidity	5...95 %
PLC:	
CPU	Cortex A7, 650 MHz
Memory	512 MB RAM, 4096 MB FLASH, 128 kB NVRAM
Memory card	unsupported, not intended to be used by user
Addressing	SW
Communication:	
Ethernet	2 × Ethernet 10/100, RJ45
Serial port	RS485
Programming enviroment	Domat IDE (ST, FBD)
Terminals	cage clamps - wire 0.2...1.5 mm ²
Analogue inputs	2 × Pt 1000, (Ni1000, 440...4400 Ω), 16 bit, -60...350 °C 2 × 0...10 V DC, 16 bit
Analogue outputs	2 × 0...10 /±10 V DC, 12 bit
Digital inputs	8 × 24V DC – need to connect DC voltage, e.g. Uout+
Input voltage „log. 0“	max. 5 V DC, 2.8 mA
Input voltage „log. 1“	11...30 V DC, 2.8 mA
Digital outputs	4 × NO, max. 0.5A, 24 V DC, max. 1 kHz
Dimensions	55 (h) × 108 (w) × 90 (h) mm
Protection degree	IP20
Material	polycarbonate, polyamide
Standards confirmity	electromagnetic compatibility (EMC)EN 61000-6-2, 61000-6-3 environmental testing EN 60068-2-42, 60068-2-43

Terminals

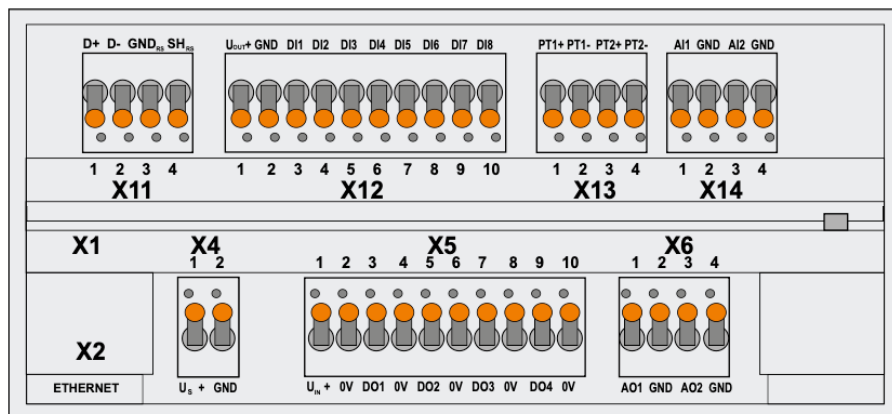

Terminals and connectors

US+ (X4)	power
GND	ground
DO1...DO4 (X5)	relay output 1...4, normally open against 0V (for proper function connect U_{S+} with U_{IN+} , and GND with 0V)
0V	relay output 0V, ground
DI1...DI8 (X12)	digital inputs 1...8
Uout+	24 V DC for DI
GND	common wire for digital inputs
PT1+, PT1- (X13)	analogue input 1 for temp. sensor
PT2+, PT2- (X13)	analogue input 2 for temp. sensor
AI1, AI2 (X14)	analogue input (voltage)
GND	analogue input ground (common) Notice: GND is common for analogue inputs, analogue outputs and supply voltage.
AO1, AO2 (X6)	analogue outputs 1 and 2
GND	analogue outputs ground (common) Notice: GND is common for analogue inputs, analogue outputs and supply voltage.
RS485 (X11)	serial line RS485, terminals D+, D-, GND – ground, SH – shielding
Eth0, Eth1 (X1, X2)	network interface

LED indication

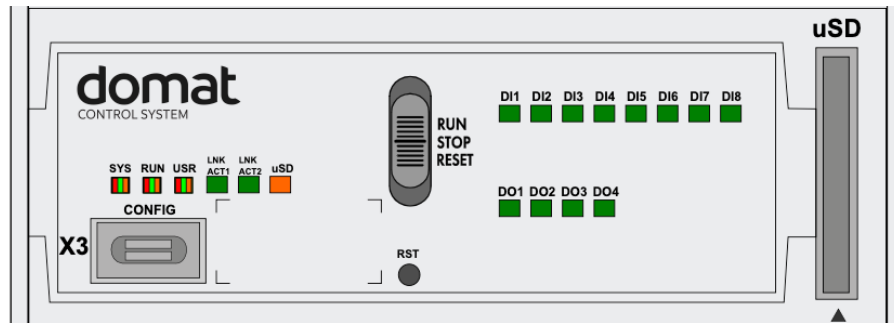

SYS	System status (red, green, off)
RUN	PLC program status (red, green, off)
USR	unused
LNK ACT1	Eth connection status (green, off)
LNK ACT2.	Eth connection status (green, off)
μSD	unused
USB C	unused
DI1...DI8	input ON (green), input OFF (off)
DO1...DO4	output ON (green), output OFF (off)

Connection

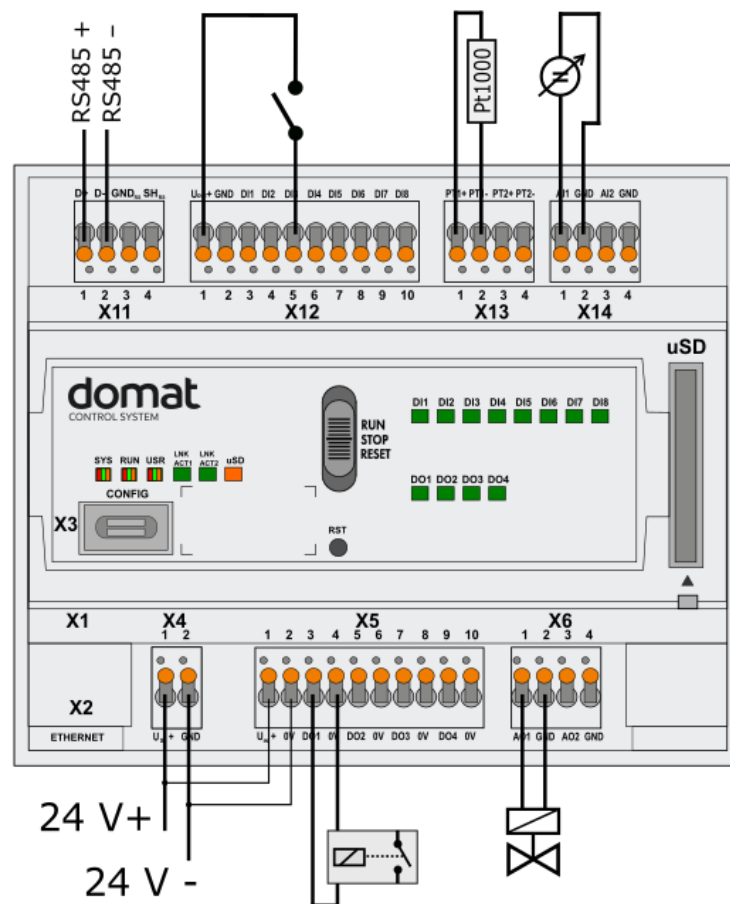

During the installation, ensure sufficient distance of controller from other components:

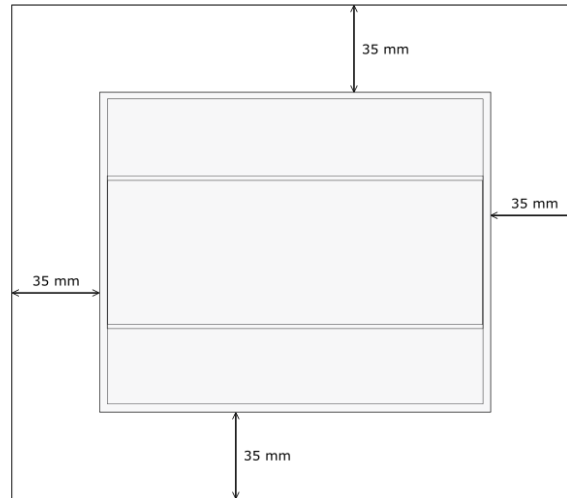

For nstandard installation max. ambient temperature is 50 °C.

Dimensions

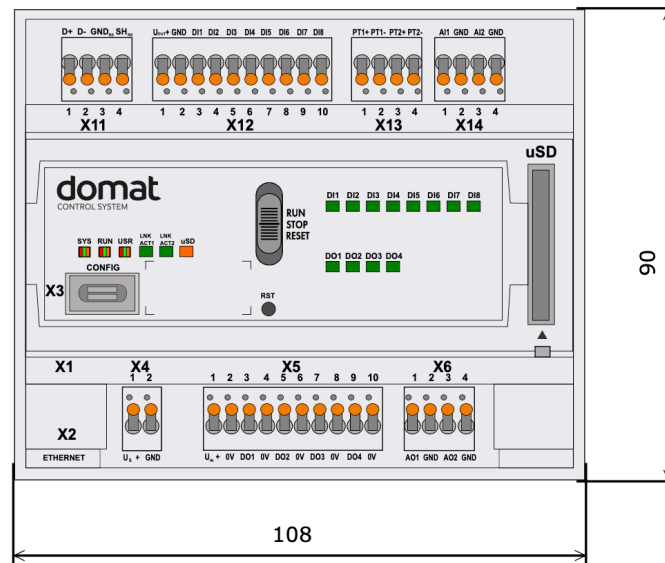

Dimensions are in *mm*.

Programming

Domat IDE

Programming tool Domat IDE contains I/O editor, graphical editor of the function plan (FBD), structure text editor, web page editor and LCD menu editor (HMI) for PLC and compiler.

The application program consists of function blocks which are stored in libraries. Those contain analogue and digital functions, mathematical blocks including goniometric functions, time schedulers, alarm blocks, and HVAC specific blocks (heat recovery, dewpoint calculation, enthalpy, pump switch etc.). In addition to function blocks, the application program can also be compiled from structured text, or a combination of both languages can be used.

The minimum guaranteed number of records for history on the PLC is 79 000, but the actual number of stored samples may be larger depending on the data types that are stored in the history.

Communication Default network settings are:

IP address: 192.168.1.10
subnet mask: 255.255.255.0
default gateway: 192.168.1.1

SSCP user: admin

Password: rw

Notice: Do not forget to record the new network settings after change!

The controllers can share variables over the Ethernet network (outside temperature, heat demands etc.) together with other PLC platforms.

The runtime provides drivers for communication with I/O modules and other subsystems which communicates e.g. through Modbus TCP/RTU (server/client), M-Bus, IEC62056-21, SSCP, SoftPLC link and BACnet IP server/client (see PICS). The complete list of drivers can be found in the Channel configuration dialogue in the most recent Domat release. Please check the required protocol features and functions with the list of implemented features in the Domat IDE help. It is also possible to program own communication drivers using the I/O library functions in structure text language.

Number of communication channels (on the serial lines and Ethernet) to I/O modules and subsystems is not directly restricted. It depends on available RAM PLC memory.

Number of connections from SSCP clients is max. 20. This includes connections from Domat IDE, Domat SCADA, HT200, mobile application Domat Visual, connection from other PLCs over SSCP etc.

Uploading a project from the Domat IDE reserves two SSCP TCP connections.

Number of connections from Modbus TCP clients on Modbus TCP server is max. 5.

In case of implementation of your own ST driver, there is limitation of max. 10 clients connected simultaneously.

Other clients channels (web etc.) are not directly restricted.

WEEE notice Should device contain any non-rechargeable battery, please return it to the manufacturer or dispose of it in compliance with local regulations, after the device is not operable.

Safety note

The device is designed for monitoring and control of heating, ventilation, and air conditioning systems. It must not be used for protection of persons against health risks or death, as a safety element, or in applications where its failure could lead to physical or property damage or environmental damage. All risks related to device operation must be considered together with design, installation, and operation of the entire control system which the device is part of.

Cyber security note

The product may influence the information and cyber security (ICS) of the control system. It is supplied in default settings. Implementation and continuous compliance with the ICS rules (e.g. creating and upload of certificates and keys, their updates and management, protection against misuse, etc.) are fully the responsibility of the control system operator. The manufacturer is not responsible for damages which originated or may originate due of wrong or insufficient implementation of ICS rules when using the device. In case of questions, please contact Domat Control System technical support.

**Changes in
versions**

10/2023 – First datasheet version.

04/2024 – Information about INIT switch removed.