

## EPC102 Heating controller, communicative



**Summary** EPC102 is a communicative room heating controller (radiator, electric heater) with one triac output and one input. It can either work autonomously or be connected to the primary controller (e.g. MiniPLC, markPLC, ...) or visualization (RcWare Vision or other SCADA system) via the Modbus RTU bus.

**Application** • Systems with radiators, electric heaters or floor heating - measuring and controlling temperatures in public rooms

**Function** The controller measures room temperature via an external temperature sensor (included). Local correction is not possible, temperature correction and operating status can be set remotely over the bus. The measured temperature range is +10 to +45 °C. The measured and entered values are processed in the PI control algorithm, the output of which is the modulating member for the triac or two-state output that controls the heating valve or electrical heating switching element. The digital input is used to connect a window contact – on activation, the controller switches to Off mode. The controller works in three modes – Comfort, Precomfort and Off. Modes differ from each other by the preset heating setpoints. The values are set over the bus.

The output can operate either as a quasi-continuous PWM controlled PI controller or a two-state (thermostat) output. Control parameters, like output mode, P and I constants, or hysteresis, are set with the ModComTool configuration software, which is free to download at [domat-int.com/en/downloads/software](http://domat-int.com/en/downloads/software).

Regulators are designed for operation in a standard, chemically non-aggressive environment. They are maintenance-free and can be mounted in any position. They are secured with 2 screws to the wall or any flat surface. There are cable holes on the

sides of the box. The lid of the box is secured with four plastic screws with a lock – it is sufficient to turn the screw by 90 ° to release it.

The controller contains real-time clock that is used for statistical functions (calculation of integrated valve opening time). This clock are not used for scheduling and are not backed up by batteries. For proper statistics calculation, regular synchronization from the parent system is required.

After the bus, the heating output can be switched off permanently if the NO valve is used (open when deenergized) and the system is shut down during the summer season.

The room temperature is measured by an external communication sensor. The sensor is connected to the controller over a two-line cable with a maximum length of 30 m.

The controllers communicate with the supervisory system via the RS485 bus using Modbus RTU protocol and therefore can be used in a number of control and monitoring systems. The Modbus table can be found in a separate document UI.../UC ... – Communication description

## Technical data

Power	24 V AC/DC ±10 %; max 1.8 W
Consumption	6 VA (of which 5 VA is reserved for the connected peripherals)
<b>Controller</b>	
<b>Communication</b>	
RS485 – Modbus RTU (slave)	RS485 (K1+, K1-) baud rates 300...115 200 bit/s, parity and bits are set over Modbus RTU default 9600, N, 8, 1 maximal bus length 1200 m maximum number of modules depends on requested response time – up to 255 addresses, for common HVAC applications use about 300...400 physical data points on the bus galvanic isolation from other modules, insulating voltage 1 kV
<b>Digital inputs</b>	
	1 × DI potential-free contact, 24 V AC, 5 mA, configurable logic
<b>Digital outputs</b>	
	1 × solid state relay for AC load, zero switching, 24 V AC, max. current 1 A. Recommended actuators are STA71 (Siemens), TWA (24 V types, Danfoss).
SW	ModComTool
Housing	ABS, RAL9010
Protection degree	IP20 (EN 60529)
Recommended wire diameter	0.35...1.5 mm <sup>2</sup>

Dimensions	97 × 97 × 42 mm
<b>Room Temperature Sensor</b>	
Sensor accuracy	±0.5 K (can be corrected)
Max. cable length to sensor	30 m
Sensor connection cable	2 × 0.5...0.8 mm <sup>2</sup>
Measuring range	10...45 °C
Protection degree	IP20
Dimensions	see below
Standards conformity	EMC EN 61000-6-2 ed.3:2005, EN 61000-6-4 ed.2:2006 + A1:2010 (průmyslové prostředí) electrical safety EN 60950-1 ed.2:2006 + A11:2009 + A12:2011 + A1:2010 + A2:2014 + Opr.1:2012 + Z1:2016 restriction of hazardous substances EN 50581:2012

## Terminals

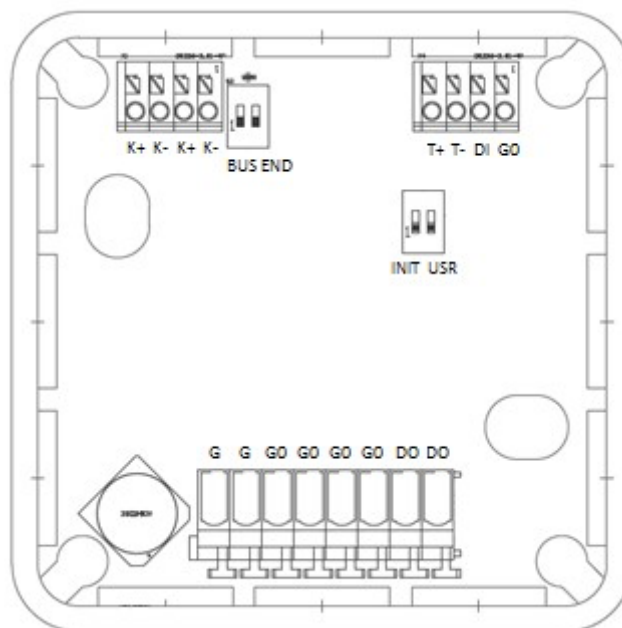

### Terminals and connectors

<b>K+</b>	serial line RS485 +
<b>K-</b>	serial line RS485 -
<b>T+</b>	Input for the communicative temperature sensor +
<b>T-</b>	Input for the communicative temperature sensor -
<b>DI</b>	presence input (switches Comfort – Precomfort)
<b>G0</b>	Outputs and inputs – reference point (internally connected to G0 in the lower row)
<b>G</b>	power
<b>G0</b>	power
<b>DO</b>	heating output, 24 V AC against G0

## DIP switches

### INIT

INIT (DIP 1) - if ON at power-up, configuration parameters are brought to defaults (address 1 communication parameters 9600/8/N/1)

Another function of the INIT switch is to bring EEPROM into default factory settings. To init the EEPROM, proceed as follows:

- connect the device over RS485 to a PC with ModComTool (Modbus Configuration Tool)
- set INIT to ON
- apply power
- find the controller in the tool (Scan)
- set INIT to OFF
- in the ModComTool, open the controller window
- click the INIT button in the tool - remove and apply power.

### USR

not used

### BUS END

Both in the ON position terminate the bus (if the controller is the last on the bus)

## Wiring

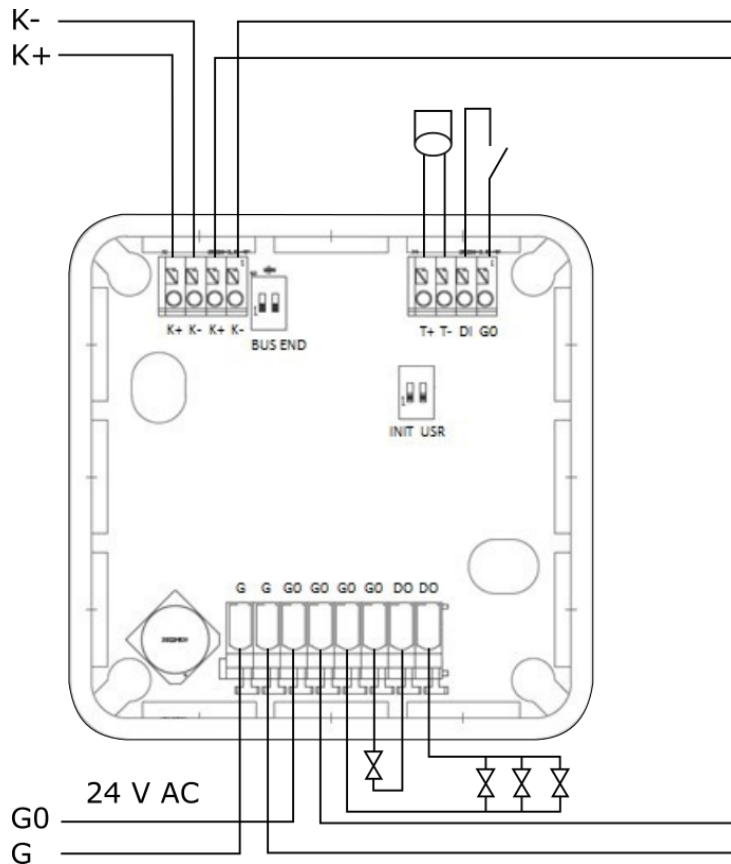

## Dimensions

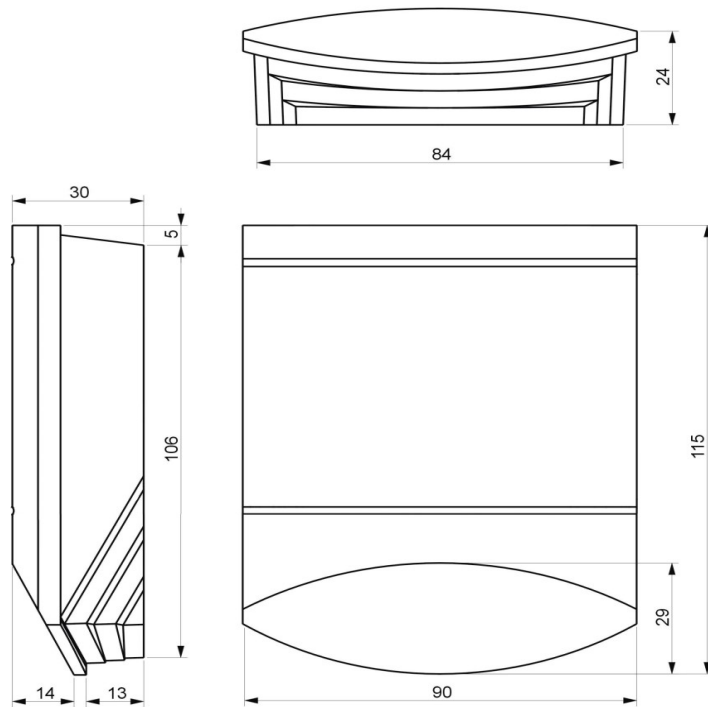

Temperature sensor. Dimensions are in *mm*.

## Installation

Suitable cable types are LAM DATAPAR 2 × 0.8 (cross-section mm<sup>2</sup>), JYTY 2 × 1 (diameter mm), etc. If the same cable is used for communication, use LAM DATAPAR 2 × 2 × 0.8, JYTY 4 × 1 four-core cables. In terms of electromagnetic immunity, it is preferable to use twisted pair cable (as is the case with the LAM DATAPAR cable).

Using the above cable types, considering the maximum (starting) power of the "regulator + valve" set of approx. 7 VA and a permissible voltage drop of up to 15 %, the maximum cable length for 10 controllers fitted with one valve each is about 50 m.

If the controller and valve are more than 50 m away from the source (transformer) or multiple valves (max. 4 valves per controller) are connected to one controller, it is recommended to provide local power supply with a separate transformer. The RS485 bus is galvanically isolated and connects all controllers regardless of how they are powered.

With larger voltage drops on the line, the thermal actuators may not provide sufficient heat output to fully open the valves. The radiators would therefore be less hot.

If the controllers are connected in series using the G-G and G0-G0 terminals, the maximum current (8 A) flowing through the PCBs between the terminals of the same name must not be exceeded.

## Function

Part of the function description is also a Modbus table in a separate document. The **description** - register numbers of the table are referenced in the text below.

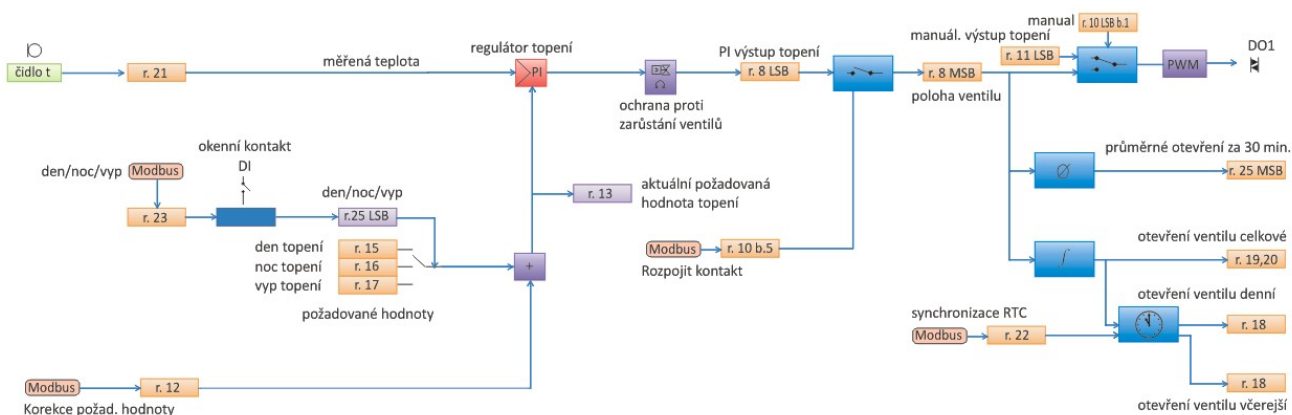

### Setting the operating mode

The default value for selecting the set values is the operating mode, which is one of the states

- Comfort (Day)
- Precomfort (Night)
- Off.

Operating mode is determined by the following factors:

- Contact brought to the DI input
- Setting over Modbus in **register 23**.

The operating mode is set directly in the register. The last written value is valid. In addition, the operating mode is affected by the state of the binary input for the window contact (switches between the Off and the remaining modes). The input is considered only when enabled (**reg. 26**). Inputs have higher priority than writing over Modbus. **The resulting operating mode is in the 25 LSB register.**

### Setpoints

According to the operating mode (Comfort, Precomfort, Off), the required heating and cooling setpoint is selected (**registers 15 to 20**). User correction is always added to these values. The correction affects all three pairs of values. Modbus correction can be written into **register 12**.

### Measured temperature

The measured temperature is the temperature of the sensor from the communicative temperature sensor.

### Regulation

In the following description, the functions described below have a higher priority, i.e., The signal is processed sequentially as it appears in the text.

### PI controllers

The current setpoint including correction and measured temperature are brought to the PI controller. This controller calculates the output signal once per second. When changing the

P or I constants at runtime, the controllers are reset, so the old integrated part is deleted and the controller integrates from zero.

#### **Valve exercising**

When this feature is enabled, the valves open once a week, regardless of the need for heating.

The resulting valve output value is available in register 8, PID output heat.

#### **Control of PWM outputs**

The output heater signal is used for PWM modulation with a period of 60 s. The **register 26 bit 7** defines whether the thermic valves are NC (normally closed, closed when deenergized, default) or NO (normally open, open when deenergized). In the case of NO, the PWM signal is inverted. The modified PWM signal is fed to the DO triac output (heating). Triac output can be manually reset. Manual override is enabled in **registers 10 bits 1 through 2**, and if the corresponding bit is active, the value from the LSB 11 manual override register is brought to the triac output, rather than the PI control signal.

#### **Continuous opening of the valve outside the heating season**

LSB register 9 serves to permanently switch off the DO outside of the heating season, so that NO valves are permanently deenergized out of the heating season. This feature has the highest priority.

**Changes in  
versions**

05/2017 – First datasheet version.  
04/2017 – Norms and photo update.  
09/2021 – Stylistic adjustments, change logo.