

MW240-B Small I/O module for lights and blinds control



Summary MW240-B is a small I/O module featuring 2 DI and 2 DO (relays). It is used for control of two lighting groups (using switches or buttons) or as a simple I/O module with no embedded bindings between inputs and outputs – the logical functionality is implemented in a master PLC.

Application

- Control of two lighting groups, with override from a PLC or SCADA over the bus
- Control of a blinds
- I/O module 2 × DI, 2 × DO for general use

Function In a plastic casing suitable for mounting into a flush box there is a board with terminals, and other components. As the device is energized the outputs set into predefined states and then are controlled either by input signals, or by bus commands, or by combination of both. Priorities may be set: the outputs permanently copy the states of the inputs (local control), or change their states as input states change (the last command is valid), with optional override over the bus.

It is also possible to set the function of bus override: relays are updated either at each change of the bus command, or at each bus command, or permanently with no regards of bus commands frequency. See details in the Modbus map (domat-int.com/en/downloads/technical-documentation/modbus-tables).

The module communicates over RS485 as Modbus RTU slave.

Technical data

Power	24 V AC/DC ± 10 %
Consumption	max. 2 W
Number of outputs (relays)	2 (NO)
Relay load	230 V AC, max. 4 A (AC1)
Connection - relays	Wires 1.5 mm ² , length 7 cm, stripped tinned ends 10 mm
Connection - others	Screw terminals, for 0.14 – 1 mm ² wires
Contact lifespan	> 10 ⁵ cycles
Inputs	for potential-free contacts, against G0
Initialization	Short - circuit terminals INIT and G0
Communication	Modbus RTU / RS485, galvanically separated (1 kV), 1200...115200 bps
Dimensions	49 × 49 × 21 mm
Ambient temperature	Working temperature of the module: 0...70 °C external influences according to EN 60721-3-3. Class 3K5 (-5...+45 °C; 5 %...95 % relative non-condensing humidity) storage according to EN 60721-3-1 Class 1K3 (-5...+45 °C; 5 %...95 % relative non-condensing humidity)
Standards of conformity	EMC EN 61000-6-2 ed.3:2005, EN 55022 ed.3:2010 (industrial environment) electrical safety EN 60950-1 ed.2:2006 + A11:2009 + A12:2011 + A1:2010 + A2:2014 + Opr.1:2012 limitation of hazardous substances EN 50581:2012

The new version MW240-B could be set to the communication INIT (Modbus address 1, 9600, N, 8) shorting terminals INIT and G0, then switch off and switch on device. For BUS END is necessary to connect an external resistor (120 Ω) to terminals K1+ and K1-.

**Dimensions
Terminals**

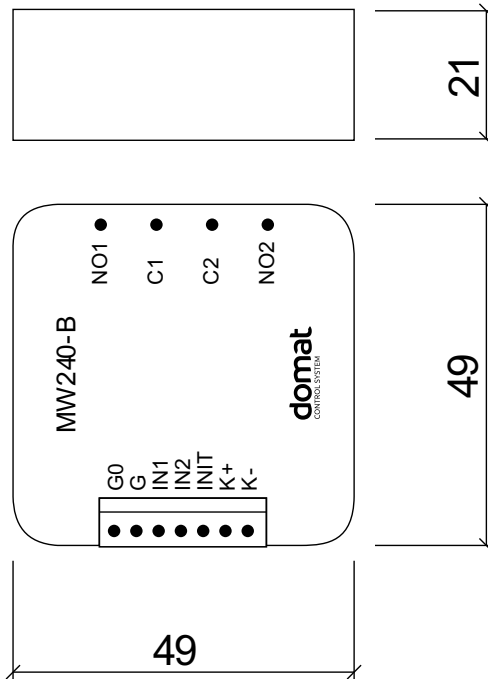

Dimensions are in *mm*.

Screw terminals

- G0 common ground
- G power supply 24 V AC/DC
- IN1 input A (referred to as Input 0 in the Modbus table)
- IN2 input B (referred to as Input 1 in the Modbus table)
- INIT initialization terminal
- K1+ RS485, +
- K1- RS485, -

Outputs (wires)

- NO1 output relay A (referred to as Relay 0 in the Modbus table)
- C1 common relay A
- C2 common relay B
- NO2 output relay B (referred to as Relay 1 in the Modbus table)

Connection

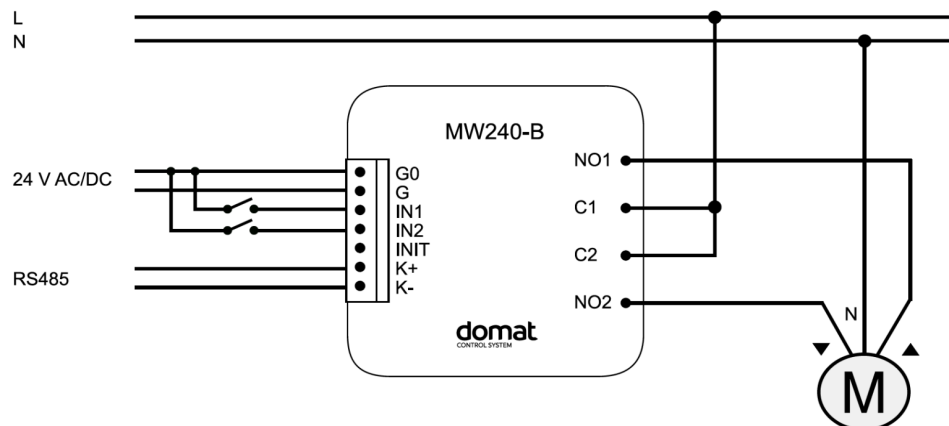

Installation

For installation of MW240-B module is recommended to use flat surface or a flush-mounting box with minimal inner diameter 65 mm and minimal depth 65 mm.

General function notes

The MW240-B controls the relays according to the states of inputs (pushbuttons or switches) and Modbus commands. Priorities and function regarding Modbus write events can be set using Modbus configuration registers, see tables below. The module can be configured for local control (switches / pushbuttons), bus control override, combined control („the last command is valid“), etc.

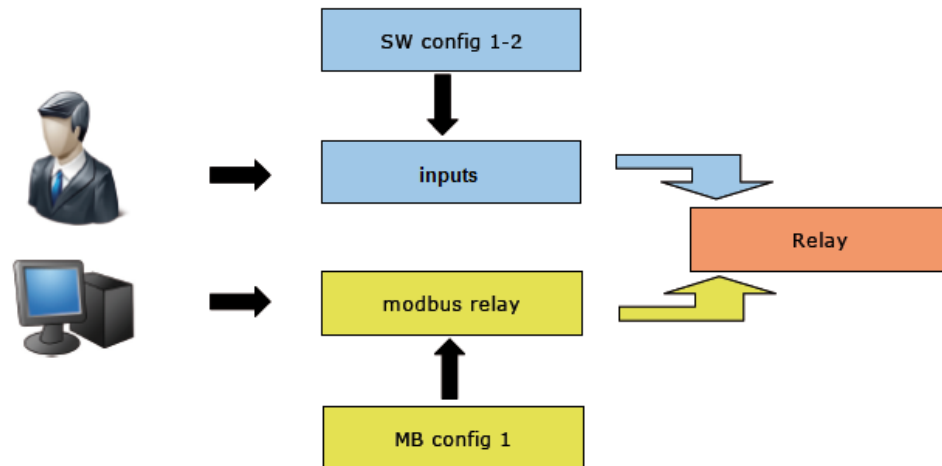

Inputs function settings

Edge

The relay status is changed at an edge on the input. Rising or falling edge is selected.

Register	Value
SW config 1	0x05
SW config 2	0x00



State change

The input state is copied to the output, the *Relay* register is written to only at a change of the input state.

Register	Value
SW config 1	0x50
SW config 2	0x00

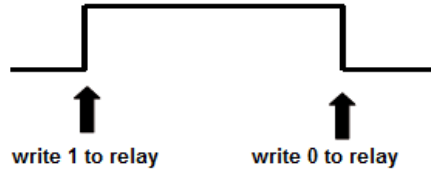

Copying of inputs

Periodically (as fast as the processor cycle allows) copies the input state to the output.

Register	Value
SW config 1	0x00
SW config 2	0x05

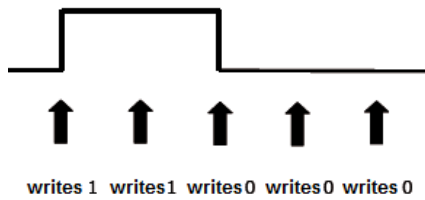

Writing from the bus

Modbus state

The *Modbus relay* values are periodically (as fast as the processor cycle allows) copied to the *Relay* register.

Register	Value
MB config 1	0x05

modbus relay

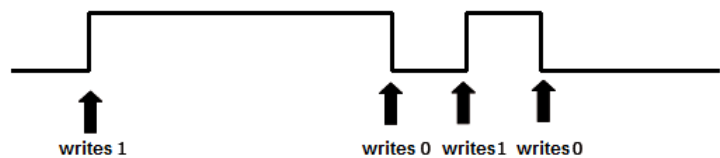

relay

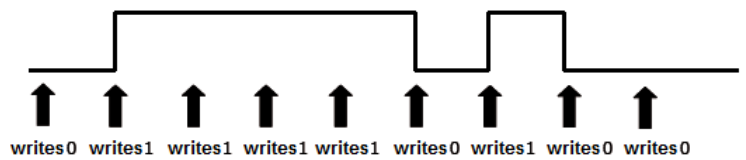

Modbus change

Each *Modbus relay* value change initiates copying of the new state into the *Relay* register.

Register	Value
MB config 1	0x0A

modbus relay

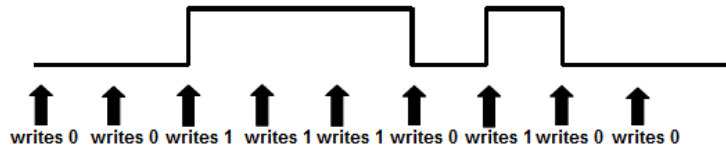

relay

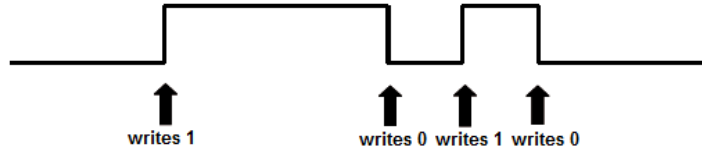

Modbus writing

Each write event into the *Modbus relay* register initiates copying of the register value into the *Relay* register.

Register	Value
MB config 1	0x0F

modbus relay

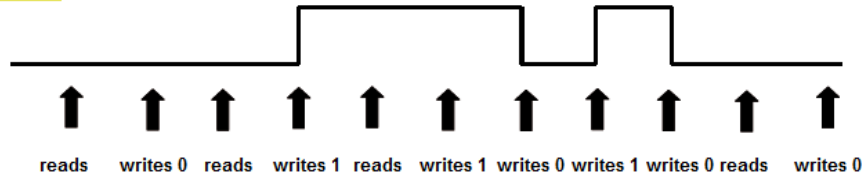

relay

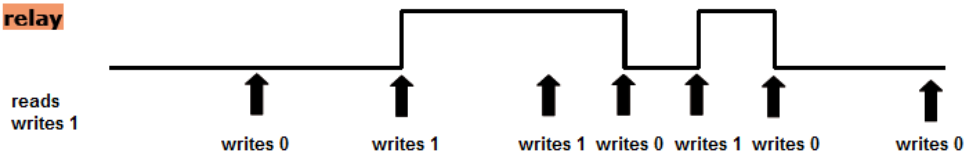

If the function **Copying of inputs** together with function **Modbus state** is selected, priority is set in the *SW/MB config 1* (6 LSB) register.

Changes

Reg. 17 has been split into two registers (25, 26) for easier value writes from the Merbon IDE. Reg. 25 contains only bit values and reg. 26 contains int value. Now it doesn't matter that the rest of the registry is overwritten with zeros.

Safety note

The device is designed for monitoring and control of heating, ventilation, and air conditioning systems. It must not be used for protection of persons against health risks or death, as a safety element, or in applications where its failure could lead to physical or property damage or environmental damage. All risks related to device operation must be considered together with design, installation, and operation of the entire control system which the device is part of.

Changes in versions

03/2015 – Changes in initialization mode, bus end, bus galvanic separation, power and relay. Modbus table is now available in separate document.

06/2016 – Added information about support higher serial communication speed.

06/2018 – *Safety note* added, front image changed, minor changes.

05/2020 – *Installation* added, main image and connection image changed, added image with dimensions and terminals.

08/2021 – Stylistic adjustments, change of logo.

05/2023 – Added info about *Changes* in relation to reg. 17.