

mark320LX
mark220LX

DDC controllers



Summary

DDC (Direct digital control) controllers mark320LX and mark220LX are free programmable process stations on i.MX platform with an ARM Cortex A7 processor and OS Linux. They are suitable for control of large installation (approximately 400 – 500 physical data points). Mark320LX contains 1 × Ethernet port, 2 × RS485 interface, and 2 × RS232 interface for connecting I/O modules. Mark220LX contains only 1 × Ethernet port and 1 × RS485 interface.

Application

- Free programmable control units for HVAC systems and other applications with local HMI and web access
- Data acquisition, processing, and presentation systems with advanced networking features
- Controls of power systems, photovoltaic power plants etc.
- Protocol converters with web data presentation (must be programmed by user)

Function

The controller hosts an embedded Linux operating system which boots up the Domat runtime with the application. The board contains real time clock with battery backup, flash memory containing OS, runtime, application, and other data (time programs, setpoints etc.), and a watchdog. It is also possible to use NVRAM to backup parameters in case of unexpected system shutdown.

The application is created and uploaded in the Domat IDE development environment. The maximum application program size depends on number of physical and software data points, amount of function blocks which require more memory (e.g. time schedulers), degree of code optimisation, and number of connections the PLC has to handle.

For communication with other devices, mark320LX contains 1 × Ethernet port, 2 × a RS485 interface and 2 × a RS232 interface. The mark220LX contains only 1 × Ethernet port and 1 × a RS485 interface.

The process station contains a web server for remote connection and user control. The web pages are created in Domat IDE through which is then web definition uploaded to the process station (see Web definition in PLC properties). Web is not recommended for safety reasons to use in free Internet. It is designed to operate on a local network. In the network topology design is therefore expected to be pre-configured router or any other element that provides network security.

The process station can be operated through a 3 × 16 characters backlit LCD display and 6 backlit pushbuttons. Users move in the menu using buttons – the **active row is the middle row**. Objects such as Value setting, Alarm, and Time schedule have predefined functionality, and thus for the configuration it is only necessary to set addresses, assign data points, and complete user texts.

The user menu structure is configured and uploaded to the process station through Domat IDE (see LCD menu definition in PLC properties).

The module is 105 mm wide and mounts on a standard DIN rail. MarkPLC kit for mounting into an aperture in panel door or any suitable box can be ordered.

Technical data

Power	24 V AC/DC ± 20 %; 6 W
Communication mark320LX	
Ethernet	1 × Ethernet 10/100BaseT RJ45, 2 LED (link, data) integrated in the connector
RS232	COM1, COM2 2 × CANNON 9 male; pin 2=RX, 3=TX, 4=DSR, 5=GND, 6=DTR, 7=RTS, 8=CTS 300...115 200 bit/s, parity and bits are set in SW
RS485	COM3, COM4 RS485 (K+, K-) 2 separated buses galvanically insulated from each other, insulating voltage 1 kV 300...115 200 bit/s, parity and bits are set in SW maximal bus length 1200 m maximum number of modules depends on requested response time – up to 255 addresses, for common HVAC applications use about 300...400 physical data points on the bus
Communication mark220LX	
Ethernet	1 × Ethernet 10/100BaseT RJ45, 2 LED (link, data) integrated in the connector
RS485	COM4 RS485 (K+, K-) 1 bus; galvanically insulated, insulating voltage 1 kV 300...115 200 bit/s, parity and bits are set in SW maximal bus length 1200 m maximum number of modules depends on requested response time – up to 255 addresses, for common HVAC

applications use about 300...400 physical data points on the bus

LCD display	3 rows × 16 characters, blue backlight manually adjustable backlight intensity possibility to switch off the backlight through application software
Buttons	6 backlit buttons
6× LED – mark320LX	RUN, PWR, 2× RS485 RxD/TxD
4× LED – mark220LX	RUN, PWR, RS485 RxD/TxD
HW	ARM i.MX6UL 528 MHz, 64 MB FLASH, 128 MB RAM, 128 kB NVRAM FRAM
SW	Domat IDE
Housing	polycarbonate box (certification UL94V0)
Dimensions	105.6 × 98.7 × 61.4 mm
Aperture dimensions	102(width) × 45 (high) mm; tolerance +1 mm
Protection degree	IP20 (EN 60529+A1+A2)
Terminals	screw terminals M3, recommended wire diameter 0.35...1.5 mm ²
Ambient temperature	from -20...50 °C; 5...85% relative humidity; non-condensing gases, chemically non-aggressive conditions, fog, ice and frost (according EN IEC 60721-3-3 ed. 2:2019 climatic class 3K22, 1K21, 3M11) for installation at high altitude, it is necessary to consider the reduction of dielectric strength and a limited cooling air (EN IEC 60664-1 ed.3: 2020)
Standards of conformity	EMC EN IEC 61000-6-2 ed. 4:2019, EN IEC 61000-6-4 ed. 3:2019 (industrial environment) electrical safety EN IEC 62368-1 ed. 2:2020+A11:2020 hazardous substances reduction EN IEC 63000:2019
Accessories	markPLCkit – frame for mounting mark320LX into an aperture in panel door or any suitable box

Terminals

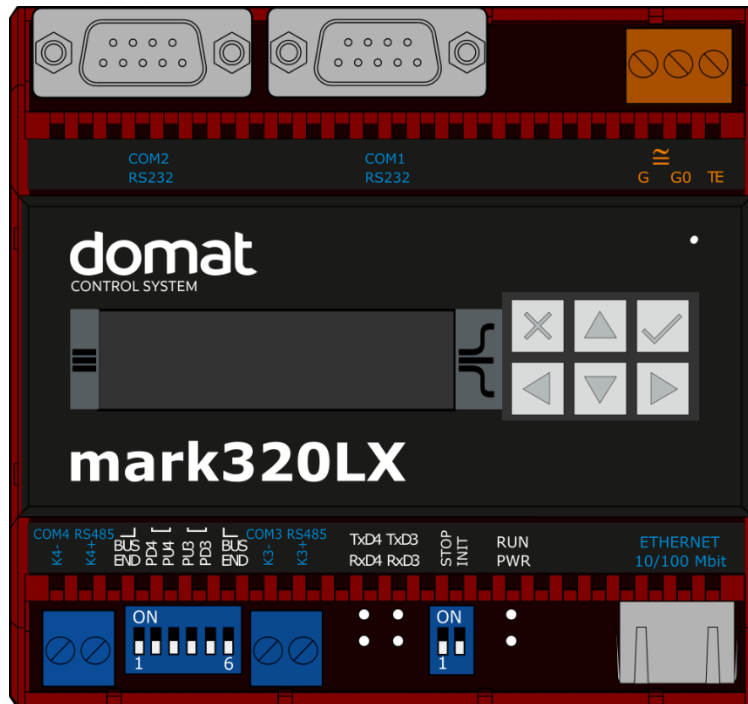

Terminals and connectors

COM1	port COM1 - serial link RS232; CANNON 9 male (mark320LX only)
COM2	port COM2 - serial link RS232; CANNON 9 male (mark320LX only)
COM3	port COM3 - serial link RS485, terminals K+, K- (mark320LX only)
COM4	port COM4 - serial link RS485, terminals K+, K-
Ethernet	network interface
G	power
GO	power
TE	optional connection for shielding (on the back side in the DIN rail groove there is a metal strip which connects TE to DIN rail after the device is snapped on the rail)

LED indication

RUN	green LED – system cycle (OK: LED flashes periodically 1 s ON, 1 s OFF; ERROR: LED flashes in other pattern, LED is still ON or OFF)
PWR	green LED – power (ON: power OK; OFF: no power applied, weak or damaged power supply, ...)
RxD3	green LED – RS485 receiving data at COM3 (flashing: receiving data; OFF: no data traffic) (mark320LX only)
TxD3	red LED – RS485 transmitting data at COM3 (flashing: transmitting data; OFF: no data traffic) (mark320LX only)
RxD4	green LED – RS485 receiving data at COM4 (flashing: receiving data; OFF: no data traffic)
TxD4	red LED – RS485 transmitting data at COM4 (flashing: transmitting data; OFF: no data traffic)

DIP switches

STOP	if ON runtime is running, program execution is stopped
INIT	if ON at power-up, configuration parameters are brought to defaults (see Configuration parameters in Domat IDE; for example IP address, user and password, database settings, proxy, ...)
BUS END	(DIP6 next to COM3 RS485) bus end COM3; the first and last devices on bus should have bus end ON
BUS END	(DIP1 next to COM4 RS485) bus end COM4; the first and last devices on bus should have bus end ON
PU3	pull-up resistor for COM3
PD3	pull-down resistor for COM3
PU4	pull-up resistor for COM4
PD4	pull-down resistor for COM4

DIP BUS END, PU/PD

Bus End and pull up / pull down switches:

Three switches on the left belong to COM4, three switches on the right belong to COM3.

Unlike for the other modules and controllers, the bus is terminated (BUS END) with one switch only (SW1 and SW6).

The inner switches (2 and 3 for COM4, 4 and 5 for COM3) are pull-up and pull-down switches for K+, and K- wires:

The K- signal is bound over a resistor to RS485 ground (PD switch), the K+ links over a resistor to +5V power of the bus driver (PU switch).

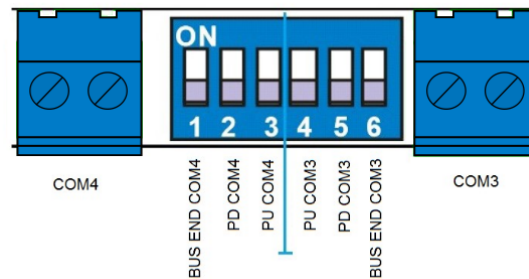

Unlike at the older PLC versions, the RS485 buses are separated from each other. It is possible to activate all PU and PD switches at the same time.

Dimensions

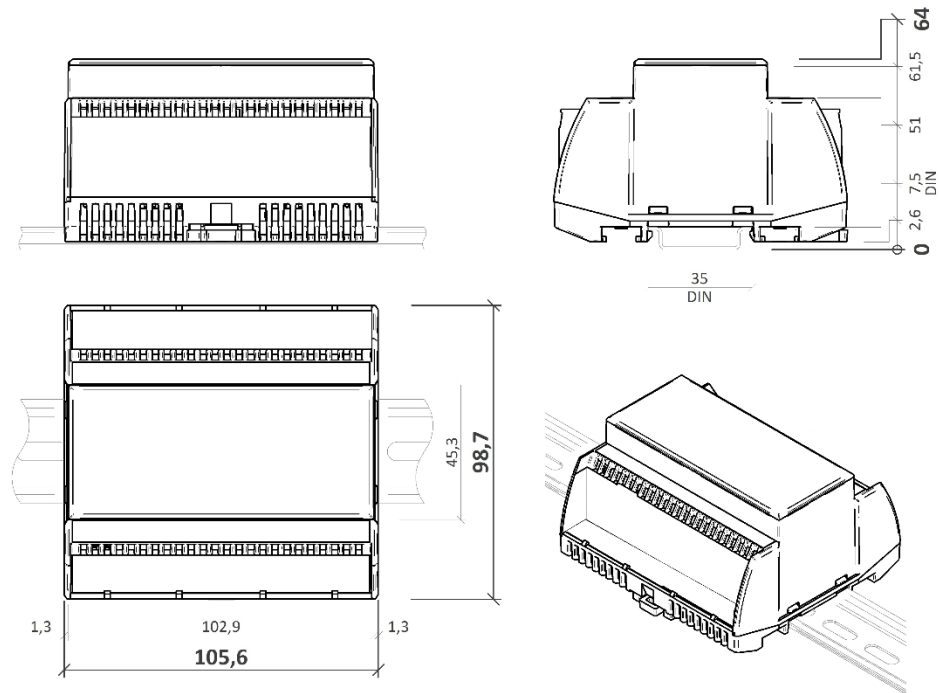

Dimensions are in *mm*.

Programming Domat IDE

Programming tool Domat IDE contains I/O editor, graphical editor of the function plan (FBD), structure text editor, web page editor and LCD menu editor (HMI) for PLC and compiler.

The application program consists of function blocks which are stored in libraries. Those contain analogue and digital functions, mathematical blocks including goniometric functions, time schedulers, alarm blocks, and HVAC specific blocks (heat recovery, dewpoint calculation, enthalpy, pump switch etc.). In addition to function blocks, the application program can also be compiled from structured text, or a combination of both languages can be used.

The minimum guaranteed number of records for history on the PLC is 37 000, but the actual number of stored samples may be larger depending on the data types that are stored in the history

Communication Default network settings are:

IP address	192.168.1.10
subnet mask	255.255.255.0
default gateway	192.168.1.1

SSCP user: admin
Password: rw

Notice: Do not forget to note the new network settings after change!

After these values have been changed, it is possible to bring the process station into default settings by the INIT DIP switch: set INIT to ON and restart the station. All values in the PLC configuration are set to defaults. The PLC will respond at the default IP address and it is possible to change the old address through Domat IDE.

The controllers can share variables over the Ethernet network (outside temperature, heat demands etc.) together with other PLC platforms.

The runtime provides drivers for communication with subsystems. For example Domat runtime contains: Modbus TCP / RTU (server/client), M-Bus, IEC62056-21, SSCP, and SoftPLC link. The complete list of drivers can be found in the Channel configuration dialogue in the most recent Domat release. Please check the required protocol features and functions with the list of implemented features in the Domat IDE help. It is also possible to program own communication drivers using the I/O library functions in structure text language.

Number of communication channels (on the serial lines and Ethernet) to I/O modules and subsystems is not directly restricted. It depends on available RAM PLC memory.

Number of connections from SSCP clients is max. 20. This includes connections from Domat IDE, Domat SCADA, HT104/200, mobile application Domat Visual, connection from other PLCs over SSCP etc.

Number of connections from Modbus TCP clients on Modbus TCP server is max. 5.

In case of implementation of your own ST driver, there is limitation of max. 10 clients connected simultaneously.

Uploading a project from the Domat IDE reserves two SSCP TCP connections.

Other clients channels (web, ...) are not directly restricted.

WEEE notice

The device contains a non-rechargeable battery which backups the real-time clock and part of the memory. After the device is not operable, please return it to the manufacturer or dispose of it in compliance with local regulations.

Safety note

The device is designed for monitoring and control of heating, ventilation, and air conditioning systems. It must not be used for protection of persons against health risks or death, as a safety element, or in applications where its failure could lead to physical or property damage or environmental damage. All risks related to device operation must be considered together with design, installation, and operation of the entire control system which the device is part of.

Cyber security note

The product may influence the information and cyber security (ICS) of the control system. It is supplied in default settings. Implementation and continuous compliance with the ICS rules (e.g. creating and upload of certificates and keys, their updates and management, protection against misuse, etc.) are fully the responsibility of the control system operator. The manufacturer is not responsible for damages which originated or may originate due of wrong or insufficient implementation of ICS rules when using the device. In case of questions, please contact Domat Control System technical support.

Changes in versions

07/2021 – First version of datasheet.

03/2022 – Logo change, stylistic modifications, added information about limiting the number of simultaneously connected clients.

09/2022 – Flash memory size correction.

10/2023 – Change of names from Merbon to Domat

04/2024 – Addition of pin descriptions for CAN 9 (RS-232) ports.