

## UT001

## Room temperature sensor



### Summary

Room temperature sensor UT001 is a passive Pt1000 sensor in plastic housing for room temperature measurement.

### Application

- Air handling units, heating systems – room temperature measurement and control
- monitoring of room temperature

### Function

Sensing elements change their electric resistance with temperature. The measuring element is a thin-layer platinum resistor: on a ceramic base there is a thin layer of pure platinum. This layer is structured by photolithography and calibrated with laser beam to achieve its nominal value. The active layer is passivated by a glass layer which prevents the platinum film from mechanical and chemical damage. The outputs are welded to the active layer. The element is installed on a PCB with terminals, which is fixed to the inside of the housing. After the sensor is installed, the top snaps on the bottom and the pins connect the element with the cabled terminals.

The sensors are intended for operating in a normal and chemically non-aggressive environment. They do not need any servicing or maintenance. They should be installed vertically to ensure proper air circulation through the apertures in the housing. The sensor consists of two parts: bottom with terminals and top with the printed circuit board and measuring element. The sensors are mounted with 2 or 4 screws on a flush-mounted junction box with 5 mm in diameter or on any flat surface. In the bottom there is a hole to bring the cable in.

It is recommended to install the bottom first and snap on the top with the sensor only after the installation works are ready to prevent damage of the sensor.

The resistance is given by the equation

$$R = 1000 (1 + At + Bt^2 + C(t - 100) t^3) \quad \text{for temperatures } -20 \dots 0 \text{ } ^\circ\text{C}$$

$$R = 1000 (1 + At + Bt^2) \quad \text{for temperatures } 0 \dots 80 \text{ } ^\circ\text{C}$$

where  $A = 3.9083 \times 10^{-3} \text{ } ^\circ\text{C}^{-1}$   
 $B = -5.775 \times 10^{-7} \text{ } ^\circ\text{C}^{-2}$   
 $C = -4.183 \times 10^{-12} \text{ } ^\circ\text{C}^{-4}$

Tolerance (Class B):

$\Delta T = \pm (0.30 + 0.005 | t |)$ , where  $| t |$  is absolute value of temperature in  $^\circ\text{C}$ .

### Technical data

Sensing element	Pt1000, $T_k = 3850 \text{ ppm}/^\circ\text{C}$
Measuring range	$-20 \div 70 \text{ } ^\circ\text{C}$
Resistance at $0^\circ\text{C}$	1000 Ohm
Protection	IP20
Sensor accuracy	according to DIN IEC 751, Class B
Long-term stability	0.05 %; 10000 hours
Recommended DC measuring current	$< 1 \text{ mA}$
Terminals	screw terminals for wires 0.14 ... 1.5 mm <sup>2</sup>
Cover	ABS
Weight	0.13 kg
Dimensions	see below
Color variants	UT001 – white UT001-A – anthracite UT001-LG – light grey UT001-DG – dark grey

### Sensor types

When designing sensor cabling, please note that the cable resistance will cause measuring error. For a 50 m cable and a Pt1000 sensor the error is as follows:

wires 0.50 mm<sup>2</sup> ... measuring error 0.90 K  
wires 0.75 mm<sup>2</sup> ... measuring error 0.60 K  
wires 1.00 mm<sup>2</sup> ... measuring error 0.44 K.

For other cable lengths, the errors are more or less linear.

### Terminals

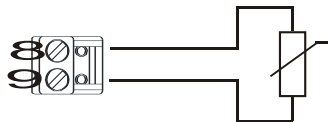

8: T1 temperature sensor  
9: T1 temperature sensor

**Dimensions**

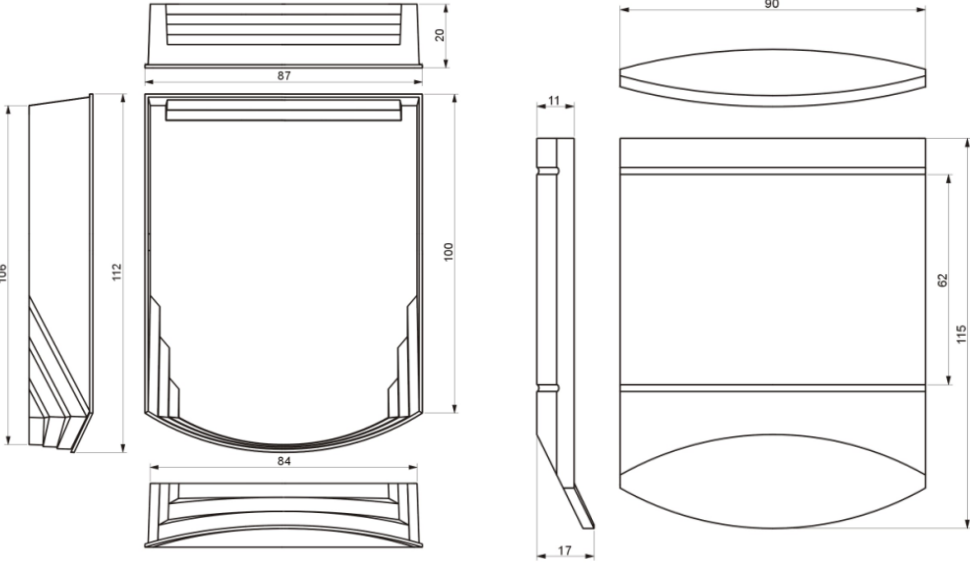

All dimensions are in *mm*.

**Changes in  
versions**

03/2015 — Modifying of sensor accuracy table, change in accuracy class and measuring error  
12/2016 – Linguistic corrections.  
12/2023 – Change of the logo, added color variants.