

## UT090

## Room temperature and CO2 sensor



### Summary

The room temperature and CO2 sensor contains NDIR CO2 sensor for measuring of carbon dioxide concentration in rooms with variable load. The output signals are analogue signals of 2× 0...10 V DC.

### Application

- Air handling units in rooms with variable load: schools, theatres, auditing halls etc...
- Monitoring and record of temperature and CO<sub>2</sub> concentration in interiors

### Function

The temperature is measured by an internal sensor, signal of which is processed in a microprocessor, and converted to normalized analogue output signal. The CO<sub>2</sub> value is measured by a communicative NDIR module, and its digital signal is converted to analogue output as well.

### Measuring range

The measuring range of the temperature sensor is 0 to +50 °C. The value is proportional to the signal of 0...10 V at the AO1 terminal. The CO<sub>2</sub> measuring range is 0...2000 or 0...5000 ppm, selectable by SW1, the measured value is a 0...10 V signal at AO2.

## Technical data

Power supply	24 V AC $\pm$ 10 % or 16 ... 35 V DC
Consumption	3 VA
Temperature measuring range *	0 ... +50 °C, $\pm$ 0.5 °C
CO <sub>2</sub> measuring range	0 ... 2000 ppm SW1 OFF (default), 0 ... 5000 ppm SW1 ON
CO <sub>2</sub> measuring accuracy	$\pm$ 30 ppm $\pm$ 5 % of measured value
CO <sub>2</sub> sensor response time (90 %)	16 s
CO <sub>2</sub> sensor autocalibration	SW2 ... ON active (Default) SW2 ... OFF inactive
Protection degree	IP20
Output	2 $\times$ 0...10 V DC
Max. output current	10 mA (with 1 kOhm load),
Short-circuit current	20 mA, permanently short-circuit proof (PTC)
Resolution	12bit D/A converter
Terminals	screw terminals for wires 0.35 ... 1.5 mm <sup>2</sup>
Cover	ABS
Color variants	UT090 – white UT090-A – anthracite UT090-LG – light grey UT090-DG – dark grey
Weight	0.15 kg
Dimensions	90 $\times$ 115 $\times$ 30 mm
Ambient temperature	External conditions: +5...40 °C; +5...95 % relative humidity; non-condensing gases and chemically non-aggressive conditions (according to EN 60721-3-3 climatic class 3K3) Storage: +5...40 °C; 5...85 % relative humidity; non-condensing gases and chemically non-aggressive conditions (according to EN 60721-3-1 climatic class 1K2)
Standards conformity	EMC EN 61000-6-2 ed.3:2005 + Cor.:2005-09, EN 61000-6-4 ed.2:2007 + A1:2011 (industrial environment) Electrical safety EN 60950-1 ed.2:2006 + A11:2009 + A12:2011 + A1:2010 + A2:2013 + Corr.1:2011-10 Hazardous substances reduction EN 50581:2012

## Terminals

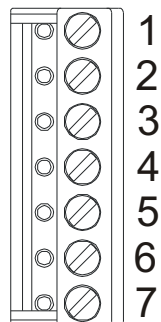

- 1: AO1 0...10 V temperature
- 2: G0 power – common point
- 3: AO2 0...10 V CO<sub>2</sub>
- 4:
- 5: GND technical earth (TE)
- 6: G0 power – common point
- 7: G power

## DIP switches

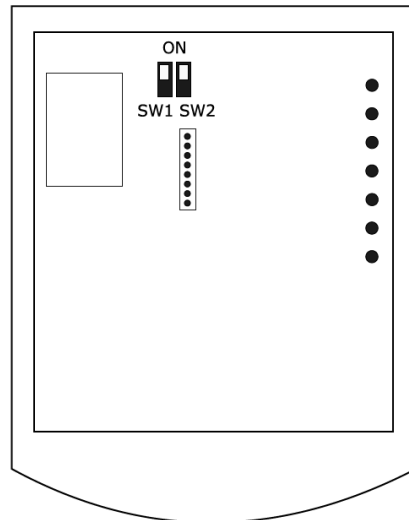

Back of the PCB

SW1

ON CO2 measuring range 0...5000 ppm  
OFF CO2 measuring range 0...2000 ppm  
(default)

SW2

ON autocalibration active (default)  
OFF autocalibration inactive

## CO<sub>2</sub> calibration

Place the sensor to an environment with a CO<sub>2</sub> concentration of 400 ppm. Disconnect power, after it switch SW1 and SW2 to the ON position. Plug in the power, switch OFF switches SW1 and SW2 to between 1 and 3 seconds after powering. The red LED flashes 5 times (1s light 1s pause), which calibrates the CO<sub>2</sub> value to 400 ppm.

## CO<sub>2</sub> autocalibration

Transportation and aging may cause sensor drift. The sensor records the lowest reading and expects that at least once per 8 days the CO<sub>2</sub> concentration reaches the outside air level (400 ppm). The lowest measured value is then assigned the 400 ppm level. Autocalibration does not work if the room is occupied 24 hours a day, or there are no periods when the gas level drops to background (e.g. greenhouses). Then, the autocalibration function can be disabled by SW2. The autocalibration is set to ON by default.

During the first days of operation, until the first autocalibration, the sensor may read values which differ from the real values by several hundreds ppm, e.g. 200 ppm at night etc. This error is automatically corrected with the first autocalibration.

## Installation

Units are intended for operating in a normal and chemically non-aggressive environment. They do not need any servicing or maintenance. Install them in a vertical position at places where they can be operated easily and measure correct values of temperature, i.e. in the height of about 150 cm, with no direct sunlight or other heat / cool source (AHU outlets, refrigerator, electrical appliances). The device consists of two parts: bottom with screw terminal block and cover containing PCB, display, and the knob. The bottom part is fixed by 2 or 4 screws to any flat surface or a flush-mounting box  $\varnothing$  60 mm. At the back of the bottom there is an aperture for cabling. The bottom should be installed and cabling connected first, and the upper part inserted after the construction works have been finished to prevent damage to the unit.

Seal the conduits to avoid influencing the sensor by draught. Use insulating pad when installing the sensor on cold walls. Avoid sensor exposition to sunlight or other heat sources.

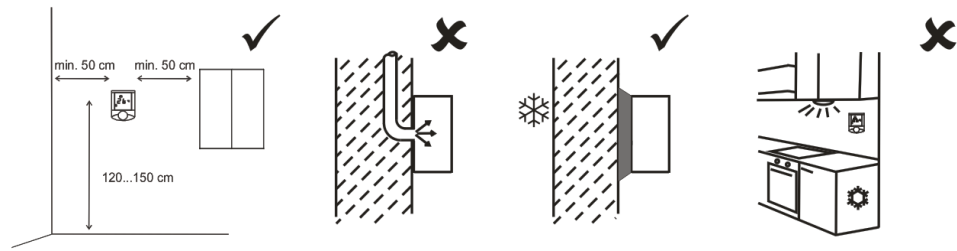

## Cover opening

When removing the display part, proceed as follows:

- press gently the side parts of the unit and pull the left of the display part by several millimeters
- pull the display part and remove it from the bottom.

Do not bend the display part too much, the connector pins could be damaged. The locks are only at the sides of the display part, not at the top nor bottom.

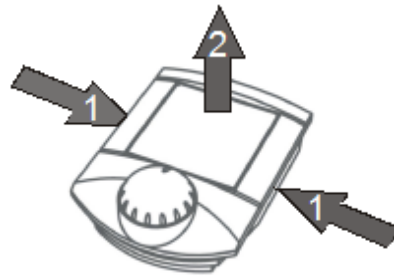

## Dimensions

### UT090

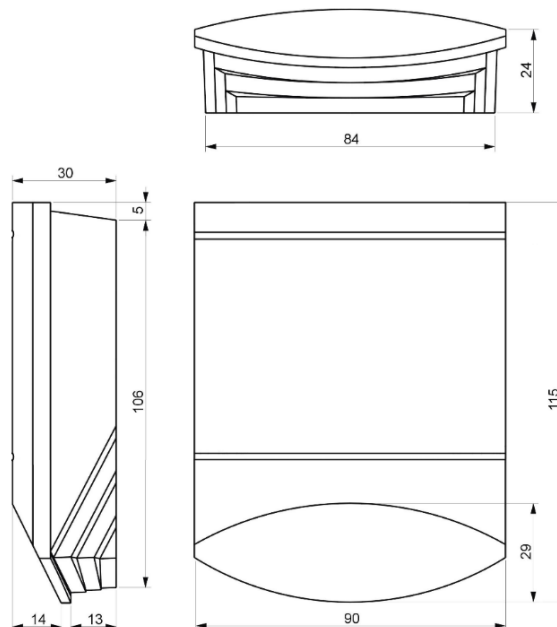

All dimensions are in *mm*.

**Safety note**

The device is designed for monitoring and control of heating, ventilation, and air conditioning systems. It must not be used for protection of persons against health risks or death, as a safety element, or in applications where its failure could lead to physical or property damage or environmental damage. All risks related to device operation must be considered together with design, installation, and operation of the entire control system which the device is part of.

\*

Sensors with following S/N have temperature measuring range -25 ... +60 °C:

193371	188707	187080
193370	188706	187079
193368	188705	187078
193363	188704	187077
193361	188703	187076
193360	188700	187074
193269	188699	187073
192504	188697	187072
192503	188696	187061
192502	188694	187060
192501	188693	187059
192500	188692	187058
192489	188677	187057
192488	188668	187056
188755	188662	187055
188752	188661	187054
188748	188659	187053
188742	187081	187052

**Changes in versions**

This datasheet applies only to devices with S/N: 182396 or higher.

05/2020 – First datasheet version.

08/2020 – Information of humidity measurement removed.

11/2020 – Change of temperature range, info about sensors with different temperature measuring range added.

12/2023 – Change of the logo, added color variants.